

PG 105 Line Pressure Regulator

PG 105 line pressure regulators are manufactured to supply the highest performance both as Line Pressure Regulators certified to ANSI Z21.80 CSA 6.22 and Gas Appliance Regulators certified to ANSI Z21.18 CSA 6.3 and feature precise regulating control. This model is available in fixed or adjustable outlet pressures where small adjustments can be made to the outlet pressure on installation with the appliance.

Features

- Precise regulating control of both full flow and of pilot flows
- Nitrile rubber diaphragm and washer are resistant to combustible gases
- Die-cast aluminum housing
- Regulators are supplied with vent limiter

Materials of Construction

Body	Aluminum/Painted
Diaphragm	Nitrile
Spring	Steel

Specifications

Inlet Pressure	2 PSIG and 5 PSIG
Outlet Pressure Setting	7" - 11" W.C.
Gases	Natural Gas or Propane
Pipe Size	3/4" x 3/4" NPT - 1" x 1" NPT
Venting	Vent Limiter
Emergency Exposure Limits	65 PSIG inlet side only
Capacity Range	960,000 BTU/h
Working Temperature	-40° to 205°F (-40° to 96°C)



ANSI/CSA CERTIFIED

Technical Note

For proper installation, the regulator must be installed in an upright position, as shown.

PG 105 Dimensions

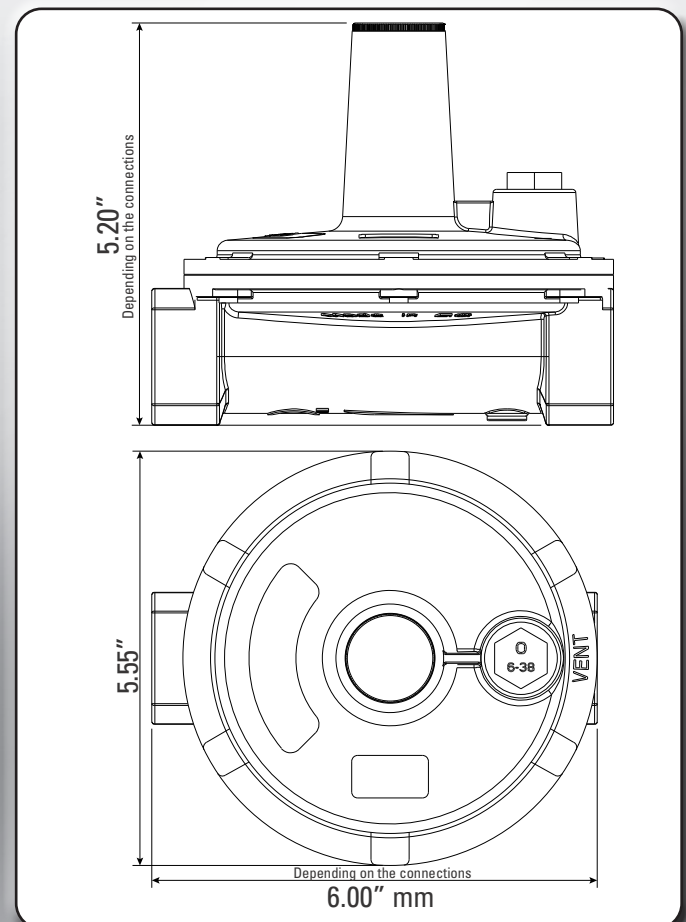

PG 105 Part Matrix

PG10	5				V	000	
	↑	↑↑	↑↑↑	↑	↑		Diaphragm
	5						5"
							Port Size
		06					3/4"
		08					1"
							Spring Range
			011				7 - 11" WC
							Inlet Rating
				2			2 PSI
				5			5 PSI
							Vent Limiter
					V		Yes

Capacities based on 1" W.C. pressure drop from set point 0.64 sp gr gas expressed in SCFH

Outlet Pressure	Inlet Pressure				
	1/2 PSIG	3/4 PSIG	1 PSIG	2 PSIG	5 PSIG
7" W.C.	364	403	447	517	645
8" W.C.	359	394	447	509	636
9" W.C.	342	381	430	500	636
10" W.C.	329	377	403	496	627
11" W.C.	302	360	372	473	614