

# L627 High Flow LP Gas Regulator



- Wide Range of Flow Capacities
- Durable Powder Coated Exterior
- Installation Versatility

The L627 is a spring loaded, direct-operated LP Gas regulator for high pressure applications in the oil and gas industries. These regulators provide durability, from the powder-coated epoxy exterior finish, as well as installation versatility, from the multi-position body and spring case configurations.

## Applications

- Fuel Gas
- Gas Gathering
- Pressure Reduction
- UL listed
- UL 144



## L627 Part Matrix

L627			0	0		0	1	0	
		↑	↑	↑	↑	↑	↑	↑	Port Size
<b>06</b>									3/4"
<b>08</b>									1"
<b>16</b>									2"
									Spring Range
									PSIG                  BAR
<b>020</b>									5 - 20                  0.34 - 1.4
<b>040</b>									15 - 40                  1 - 2.8
									Orifice
							<b>4</b>		1/4"
							<b>6</b>		3/8"
							<b>8</b>		1/2"

## Specifications

Maximum Inlet Body Pressure		
Orifice (All Orifice Sizes)	250 PSIG	
Nitrile Seat	250 PSIG	All Units
Body Sizes	3/4 NPT	
	1 NPT	
	2 NPT	
Orifice Sizes	1/4"	
	3/8"	
	1/2"	
Output	5-20 PSIG	
	15-40 PSIG	
Temperature Range	-20° to 180°F	(-29° to 82°C)
Weight Approximate		
1"	5.3 lbs	2.39 kg
2"	8.8 lbs	3.96 kg

## Materials of Construction

Body, Bonnet, Diaphragm Case	
Options	Cast Ductile Iron Body / Aluminum Bonnet & Diaphragm Case
Diaphragm	
Option	Nitrile
Seat	
	Nitrile
Orifice	
	Aluminum

Maximum Bonnet and Diaphragm Casing Pressure	L627	
	PSIG	BAR
Maximum pressure to spring and diaphragm casing to prevent leak to atmosphere (internal parts damage may occur).	250	17.2
Maximum diaphragm casing overpressure to prevent damage to internal parts.	60	4.1

## L627 Regulator Rebuild Kit

	Kit Includes	Part Number
L627 Low Pressure	Nitrile diaphragms (2), Nitrile valve disk, O'rings, back-up rings, and retaining pin	971-627-L00

**L627 Flow Capacities** (0.6 S.G.) in SCFH<sup>1</sup>

Outlet Pressure Range	Outlet Pressure Setting		Inlet Pressure		3/4" Body Size			1" Body Size		
					Port Diameter, inches			Port Diameter, inches		
	PSIG	BAR	PSIG	BAR	1/4	3/8	1/2	1/4	3/8	1/2
5 to 20 psig <sup>2</sup> (0.34 to 1.4 BAR)	5 <sup>3</sup>	0.34	10	0.69	1060	1540	1900	1100	1900	2500
			15	1.0	1300	2150	3350	1600	2500	3350
			20	1.4	1800	3050	4350	2060	3400	4450
			30	2.1	2490	3880	6850	2800	4750	6900
			60	4.1	4240	6270	7370	4710	8140	13,700
			75	5.2	5100	6620	7700	5710	9790	14,500
	10	0.69	100	6.9	5980	7440	7900	7310	12,500	16,000
			15	1.03	1290	2100	3300	1590	2480	3300
			20	1.4	1790	3000	4300	2050	3380	4410
			30	2.1	2480	3860	6830	2800	4720	6840
			60	4.1	4240	6270	7370	4710	8140	13,700
			75	5.2	5100	6620	7700	5710	9790	14,500
	20	1.4	100	6.9	5980	7440	7900	7310	12,500	16,000
			150	10.3	7130	8180	8200	10,500	17,000	18,000
			200	13.8	7250	8200	8300	13,700	18,000	18,500
			30	2.1	2490	4360	6290	2580	4360	6290
			50	3.4	4010	7870	8500	4090	7870	14,100
			60	4.1	4680	8340	8940	4750	9690	14,500
15 to 40 PSIG (1.0 to 2.8 BAR)	40	2.8	100	6.9	7220	11,500	12,600	7310	13,900	23,300
			150	10.3	10,400	12,100	13,100	10,500	17,700	34,200
			200	13.8	12,000	13,200	13,700	13,700	26,600	39,100
			60	4.1	4350	8140	9420	4510	9290	9420
			75	5.2	5510	10,300	13,600	5640	10,800	16,500
			100	6.9	7220	13,200	15,300	7310	14,700	21,900
			150	10.3	10,400	17,400	18,200	10,500	20,500	34,500
			200	13.8	13,500	18,000	18,500	13,700	27,100	46,400

1. Capacity is based on 20 percent droop unless otherwise noted below.
2. For pressure setting under 10 PSIG (0.69 BAR) limit the input pressure to 100 PSIG (6.9 BAR) to obtain the setpoint.
3. For 5 PSIG (0.34 BAR) pressure set point, the droop is 2 PSIG (0.14 BAR)

Outlet Pressure Range	Outlet Pressure Setting		Inlet Pressure		L627 – 2" Body Size		
					Port Diameter, inches		
	PSIG	BAR	PSIG	BAR	1/4	3/8	1/2
5 to 20 psig <sup>2</sup> (0.34 to 1.4 BAR)	5 <sup>3</sup>	0.34	10	0.69	1080	1700	2400
			15	1.0	1250	1900	2700
			20	1.4	1900	2650	3900
			30	2.1	2800	3680	6500
			60	4.1	4750	7250	17,800
			75	5.2	5700	8060	22,400
	10	0.69	100	6.9	7310	16,200	28,700
			15	1.03	1220	1860	2670
			20	1.4	1880	2610	3830
			30	2.1	2760	3640	6460
			60	4.1	4750	7250	17,800
			75	5.2	5700	8060	22,400
	20	1.4	100	6.9	7310	16,200	28,700
			150	10.3	10,500	23,300	25,900 <sup>5</sup>
			200	13.8	13,700	22,700 <sup>5</sup>	24,000 <sup>5</sup>
			30	2.1	2350	4300	6110
			50	3.4	4040	7100	12,800
			60	4.1	4750	8400	15,700
			100	6.9	7310	16,200	28,700
			150	10.3	10,500	23,300	29,000 <sup>5</sup>
			200	13.8	13,700	24,000 <sup>5</sup>	33,000 <sup>5</sup>

1. Capacity is based on 20 percent droop unless otherwise noted below.
2. For pressure setting under 10 PSIG (0.69 BAR) limit the input pressure to 100 PSIG (6.9 BAR) to obtain the setpoint.
3. For 5 PSIG (0.34 BAR) pressure set point, the droop is 2 PSIG (0.14 BAR)
5. Capacities are based on 25 percent boost if setting is less than 12 PSIG (0.8 BAR), 3 PSIG (0.2 BAR) boost if setting is from 12 to 60 PSIG (0.2 to 4 BAR), and 5 percent boost if setting is greater than 60 PSIG (4 BAR).

Outlet Pressure Range	Outlet Pressure Setting		Inlet Pressure		L627 – 2" Body Size		
					Port Diameter, inches		
	PSIG	BAR	PSIG	BAR	1/4	3/8	1/2
15 to 40 PSIG (1.0 to 2.8 BAR)	40	2.8	60	4.1	4370	8680	13,300
			75	5.2	5540	11,900	19,300
			100	6.9	7310	16,200	25,400
			150	10.3	10,500	23,300	41,300
			200	13.8	13,700	30,400	53,900

1. Capacity is based on 20 percent droop unless otherwise noted below.
5. Capacities are based on 25 percent boost if setting is less than 12 PSIG (0.8 BAR), 3 PSIG (0.2 BAR) boost if setting is from 12 to 60 PSIG (0.2 to 4 BAR), and 5 percent boost if setting is greater than 60 PSIG (4 BAR).

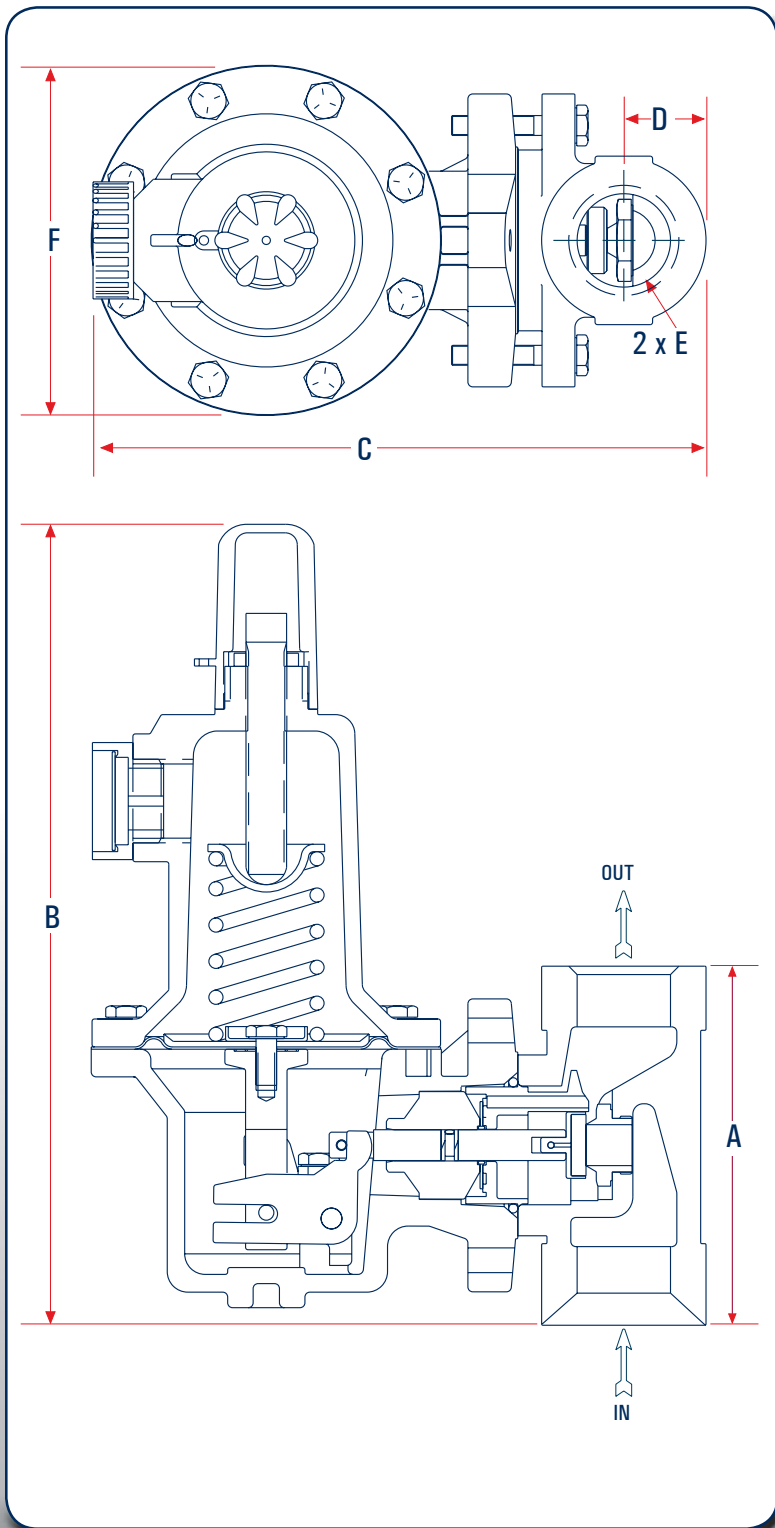

Type	Body Size		A	B	C	D	E	F*	
L627	3/4"	mm	104	243	190	26	3/4"	108	
		inches	4.08	9.54	7.46	1.0		4.25	
	1"	mm	104	243	190	26	1"	108	
		inches	4.08	9.54	7.46	1.0		4.25	
	2"	mm	mm	127	256	218	43	2"	108
			inches	5.0	10.06	8.56	1.69		4.25

**L627 Flow Coefficients**

Orifice Size		3/4 Inch Body			1 Inch (DIN 25) Body			2 Inch (DIN 50) Body			K
Inches	mm	Wide-Open C <sub>0</sub> for External Relief Sizing	Wide-Open C <sub>v</sub> for External Relief Sizing	C <sub>1</sub>	Wide-Open C <sub>0</sub> for External Relief Sizing	Wide-Open C <sub>v</sub> for External Relief Sizing	C <sub>1</sub>	Wide-Open C <sub>0</sub> for External Relief Sizing	Wide-Open C <sub>v</sub> for External Relief Sizing	C <sub>1</sub>	
1/4	6.4	50	1.63	30.5	50	1.71	29.3	52	1.66	31.3	0.76
3/8	9.5	108	2.99	36.1	108	3.42	31.6	115	3.39	33.9	0.79
1/2	12.7	190	4.87	39.0	190	5.29	35.9	200	5.01	39.9	.074

# L627 Parts

Item	Description	Part Number
1	Cover Adj. Screw, plastic	610-053-000
2	Adjustment Screw	648-465-000
3	Locknut	634-154-000
4	Bonnet, L627 - Aluminum	604-258-000
5	Vent Screw Assembly	836-005-000
6	Spring Guide, Upper	626-079-000
7	Range Spring	
	5-20 PSIG--Yellow	655-661-000
	15-40 PSIG--Green	655-661-001
8	Spring Guide, Lower	643-191-000
9	Build Screw, Spring Case (8 required)	
	L627 - Aluminum	648-466-000
10	Diaphragm Piston	637-306-000
11	Diaphragm	
	Aluminum/Iron Case (Nitrile)	618-093-000
12	Screw, Diaphragm	648-466-002
13	Post, Pusher	827-005-000
14	Diaphragm Case - Aluminum	629-202-000
15	Lever	703-004-000
16	Lever Screw (2 required)	648-466-002
17	Pin, Lever	635-053-000
18	Lever Retainer	643-192-001
19	Stem O-ring, Nitrile	649-000-003
20	Stem Backup Ring, TFE (2 required)	644-047-000

Item	Description	Part Number
21	Pin, Groove	635-054-000
22	Stem Guide	626-083-000
23	Pin Clip	635-055-000
24	Stem, 316SS	689-005-000
25	Diaphragm Case O-ring, Nitrile	649-280-000
26	Boost Body	686-003-000
27	Stabilizer, Nitrile	649-278-000
28	Seat assembly - Aluminum holder/nitrile disk	822-037-000
29	Orifice - Aluminum	
	1/4"	688-013-002
	3/8"	688-013-001
	1/2"	688-013-000
30	Body - Ductile Iron	
	3/4 NPT	664-280-000
	1 NPT	664-280-001
	2 NPT	664-282-000
31	Nameplate (not shown)	632-474-000
37	Build Screw, 3/4" & 1" Aluminum unit (2 required)	648-466-001
	Build Screw 2" Aluminum Unit (2 required)*	648-466-003
	*For 648-466-003 only, order 662-000-023 Lock Washer.	
39	Thread Locker	Consult factory
40	Name Plate Drive Screw (2 required) (not shown)	648-464-000

