

# PSX2 Slam Shut Device

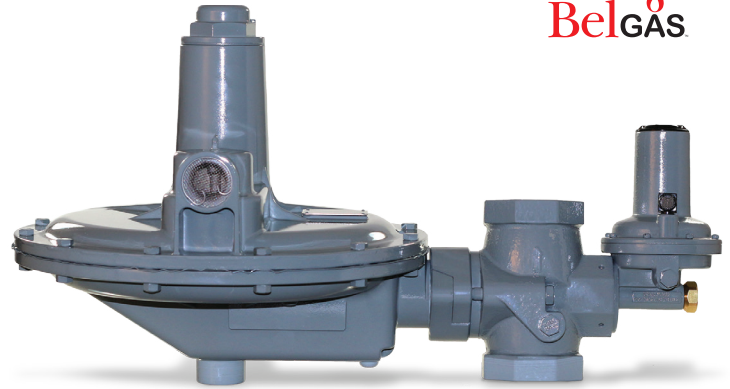

Helping critical protection of downstream operations, the BelGAS PSX2 Over/Under slam shut device is now available for the P200 and P300 series regulators. Operating on preset values, the PSX2 automatically stops downstream flow should pressure exceed the upper or lower set limits. Should the PSX2 be tripped, due to an over/under pressure condition, a manual reset is required.

Over/Under closure devices protect downstream operations and equipment should the outlet pressure of the main regulator exceed the set point. It also assures that when gas pressure drops below the set point for maintaining pilot light or critical flow, gas flow is shut down until a manual reset and inspection takes place.



## Applications

- Industrial/Commercial
- Gas Engines
- Service Regulators

## Features

- Internal or External registration
- Over/Under Pressure protection
- Manual Reset

## Materials of Construction

Body	Ductile Cast Iron
Bonnet	Aluminum
Housing	Aluminum
Diaphragm	Nitrile
Molded Seat Assembly	Nitrile and Aluminum
Orifice	Aluminum
Adjusting Nuts	Brass

**For all applicable flow rates for the P200 or P300 series regulators with the PSX2 device, refer to the flow charts in the P201/P202 or the P301/P302 standard regulator literature.**

## Specifications

Maximum Inlet	See Table 1
Maximum Emergency Outlet	15 PSIG
Pressures Ranges	See Table 2
Port Sizes	1.25 NPT
	1.5 NPT
	1.5 X 2 NPT
	2 NPT
Orifice Sizes	1/4"
	3/8"
	1/2"
	3/4"
	1"
	1-3/16"
End Connections	150 RF Flange
	125 FF Flange
	NPT
Temperature Range	-20 °F to 180 °F
	-29 °C to 82 °C
Approx. Weight	30 LBS / 14 KG

## PSX2 Ranges

Under Pressure Range	Over Pressure Range
2 - 12" WC / 4.9 - 29.9 mBAR	12 - 25" WC / 29.9 - 62.3 mBAR
4 - 30" WC / 9.9 - 74.7 mBAR	20 - 52" WC / 49.8 - 129.5 mBAR
10" WC - 2.3 PSIG / 24.9 - 159.4 mBAR	1.4 - 3.9 PSIG / 96.5 - 268.9 mBAR
1.5 - 10.8 PSIG / 103.4 - 744.6 mBAR	3.8 - 8.7 PSIG / 262.0 - 600.0 mBAR
	5.8 - 16 PSIG / 399.9 - 1,103.0 mBAR

Orifice Size	Range	Maximum Inlet Pressure
1/4"	Any	125 PSIG
3/8"	Any	125 PSIG
1/2"	Any	100 PSIG
3/4"	Any	60 PSIG
1"	2 - 4.5" thru 14-30" WC	25 PSIG
	1-2 thru 4-10 PSIG	30 PSIG
1-3/16"	2 - 4.5" thru 14-30" WC	13 PSIG
	1-2 thru 1.5 - 3.25 PSIG	14 PSIG
	2-5 thru 2 - 5.5 PSIG	20 PSIG
	4 - 10 PSIG	25 PSIG

Spring Range		Spring Color	Part Number
"WC or PSIG	BAR		
2 - 4.5" WC	0.005 - 0.011	Brown	655-697-002
3.5 - 6.5" WC	0.009 - 0.016	Red	655-697-003
5 - 9" WC	0.012 - 0.022	Black	655-697-004
8.5 - 18" WC	0.021 - 0.045	White	655-697-005
14 - 30" WC	0.035 - 0.075	Dark Green	655-697-006
1 - 2 PSIG	0.069 - 0.138	Dark Blue	655-697-007
1.5 - 3.25 PSIG	0.103 - 0.224	Orange	655-697-008
2 - 5 PSIG	0.138 - 0.345	Yellow	655-697-009
2 - 5.5 PSIG	0.138 - 0.379	Green	655-659-003
4 - 10 PSIG	0.276 - 0.689	Grey	655-697-010

## Slam Shut Valve

### How It Works

The slam shut valve type PSX2 provides downstream protection by immediately shutting off the gas flow in case of an over or under pressure situation. The PSX2 is available with either internal or external registration. For external registration, a downstream sensing line will be required.

The slam shut valve disk is held in the open position by a ball pressing against the closing shaft. If the pressure underneath the diaphragm reaches the over/under pressure setpoints, the diaphragm will move up or down and cause the ball to be released. The spring force on the stem causes the valve to shut and stop the flow of gas. Once tripped the PSX2 requires a manual reset to reintroduce the flow downstream.

### Over Pressure

The larger spring controls the over-pressure setpoint of the slamshut device. The spring adjustment tool is used to set the spring to the desired tripping pressure. No matter how strong the over pressure spring is it will not conflict with under pressure tripping due to the spring only being able to travel in the upward direction. When the pressure under the diaphragm overcomes the spring force, the diaphragm will lift upwards causing the lever mechanism to release the ball, closing the valve.

### Under Pressure

The smaller spring controls the under-pressure setpoint of the slam shut device. The spring adjustment tool is used to set the spring to the desired tripping pressure. The under pressure spring always needs to be set at a lower tripping pressure than the over pressure spring, or the slam shut will not function properly. Normally, the under pressure spring pushes down on the diaphragm. When the pressure under the diaphragm can no longer balance out the spring force the diaphragm will move downward causing the tripping mechanism to release the ball, closing the valve.

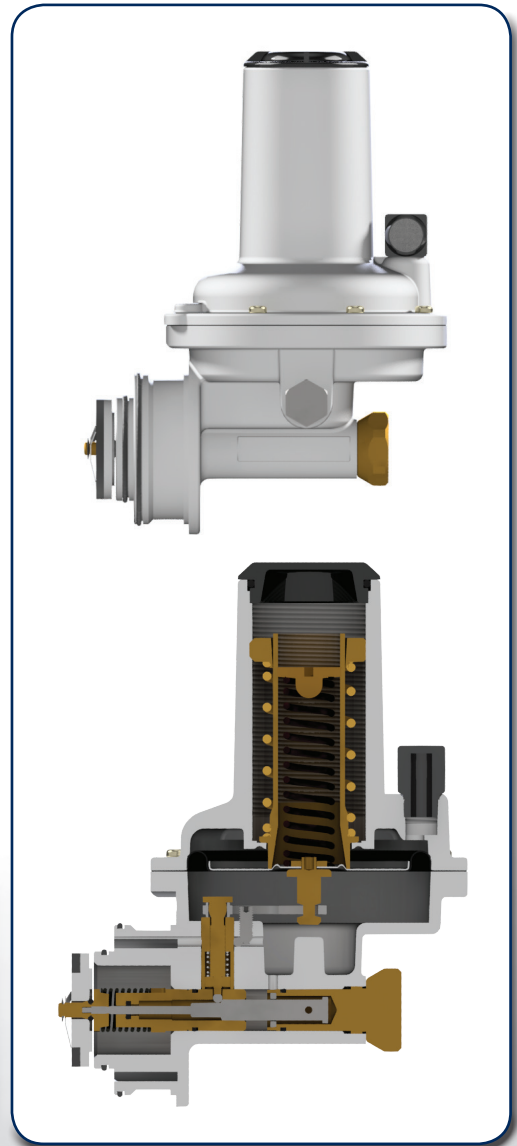

## PSX2 Dimensions

Fig. 1

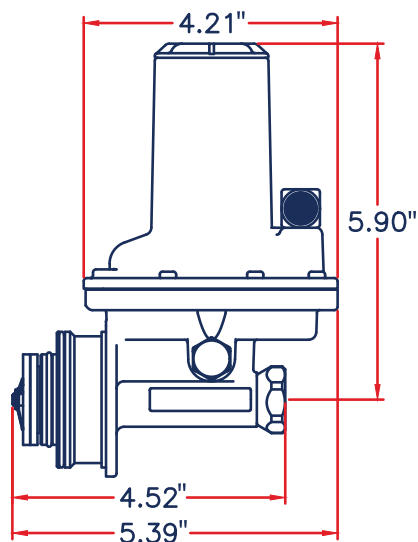

**P208/P209 Dimensions**

**Fig. 2**

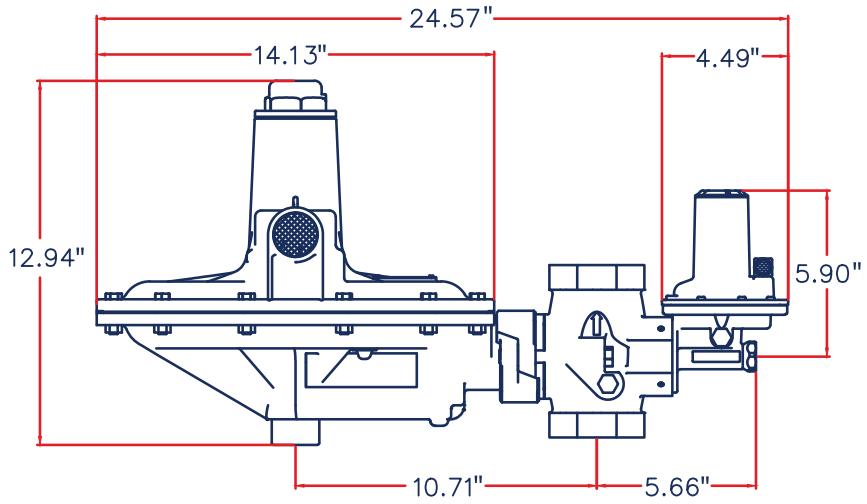

**P308/P309 Dimensions**

**Fig. 3**

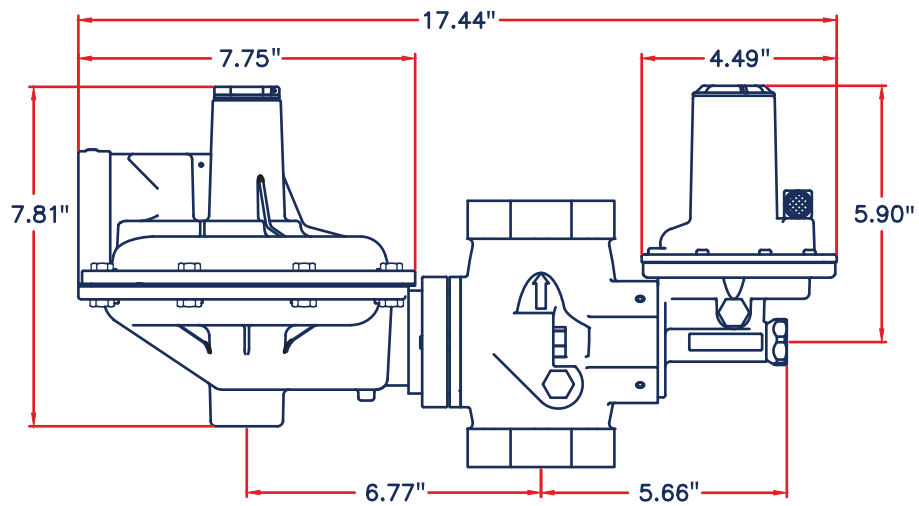



### P308/P309 Part Matrix

P30	↑	↑	↑	↑	↑	↑	↑	↑	↑	Version
8										Non-Relieving
9										Relieving
										Port Size
	12									1.25" NPT
	14									1.5" NPT
	15									1.5" x 2" NPT
	16									2" NPT
	17									2" 15ORF (Steel Only)
	18									2" 125FF (Iron Only)
										Spring Range - WC or PSIG / mBAR
	006									3" - 6" WC / 7.4 - 14.9
	085								Normal	4.5 - 8 PSIG / 310.3 - 551.6
	014									6" - 14" WC / 14.9 - 34.8
	028									12" - 28" WC / 29.8 - 69.7
	002									1 - 2 PSIG / 68.9 - 137.9
	003								High	1.5 - 3 PSIG / 103.4 - 206.8
	005									2 - 5.5 PSIG / 137.9 - 379.2
	008									4.5 - 8 PSIG / 310.3 - 551.6
										Orifice
		3								3/16"
		4								1/4"
		6								3/8"
		8								1/2"
		B								3/4"
										Port Orientation
			1							Up (Standard)
			2							Down
			3							Right
			4							Left
										Bonnet Orientation
				C						12 O'clock
				D						3 O'clock (Standard)
				E						6 O'clock
				F						9 O'clock
										Body Material
					0					Iron
					2					Steel
										Slam Shut Registration
						0				Internal
						1				External
										Under Range - WC or PSIG / mBAR
							0			None
							1			2 - 12" WC / 4.9 - 29.9
							2			4 - 30" WC / 9.9 - 74.7
							3			10" WC - 2.3 PSIG / 24.9 - 159.4
							4			1.5 - 10.8 PSIG / 103.4 - 744.6
										Over Range - WC or PSIG / mBAR
								5		12 - 25" WC / 29.9 - 62.3
								6		20 - 52" WC / 49.8 - 129.5
								7		1.4 - 3.9 PSIG / 96.5 - 268.9
								8		3.8 - 8.7 PSIG / 262.0 - 599.8
								9		5.8 - 16 PSIG / 399.9 - 1,103.0

## PSX2 Replacement Assembly Matrix

971 PSX	10	
	↑	Under Range - WC or PSIG / mBAR
1		2 - 12" WC / 4.9 - 29.9
2		4 - 30" WC / 9.9 - 74.7
3		10" WC - 2.3 PSIG / 24.9 - 159.4
4		1.5 - 10.8 PSIG / 103.4 - 744.6
		Over Range - WC or PSIG / mBAR
5		12 - 25" WC / 29.9 - 62.3
6		20 - 52" WC / 49.8 - 129.5
7		1.4 - 3.9 PSIG / 96.5 - 268.9
8		3.8 - 8.7 PSIG / 262.0-599.8
9		5.8 - 16 PSIG / 399.9 - 1,103.0

## PSX2 Springs



Under Pressure Spring Code	Over Pressure Spring Code	Main Spring Ranges
0	5	2 - 4.5" WC
0	5 or 6	3.5 - 6.5" WC
1	5 or 6	5 - 9" WC
1 or 2	6 or 7	8.5 - 18" WC
2	6 or 7	14 - 30" WC
2 or 3	7 or 8	1 - 2 PSIG
2 or 3	7 or 8	1.5 - 3.25 PSIG
3 or 4	8	2 - 5 PSIG
3 or 4	8	2 - 5.5 PSIG
4	9	4 - 10 PSIG

## PSX2 Parts - Bodies - P208/P308

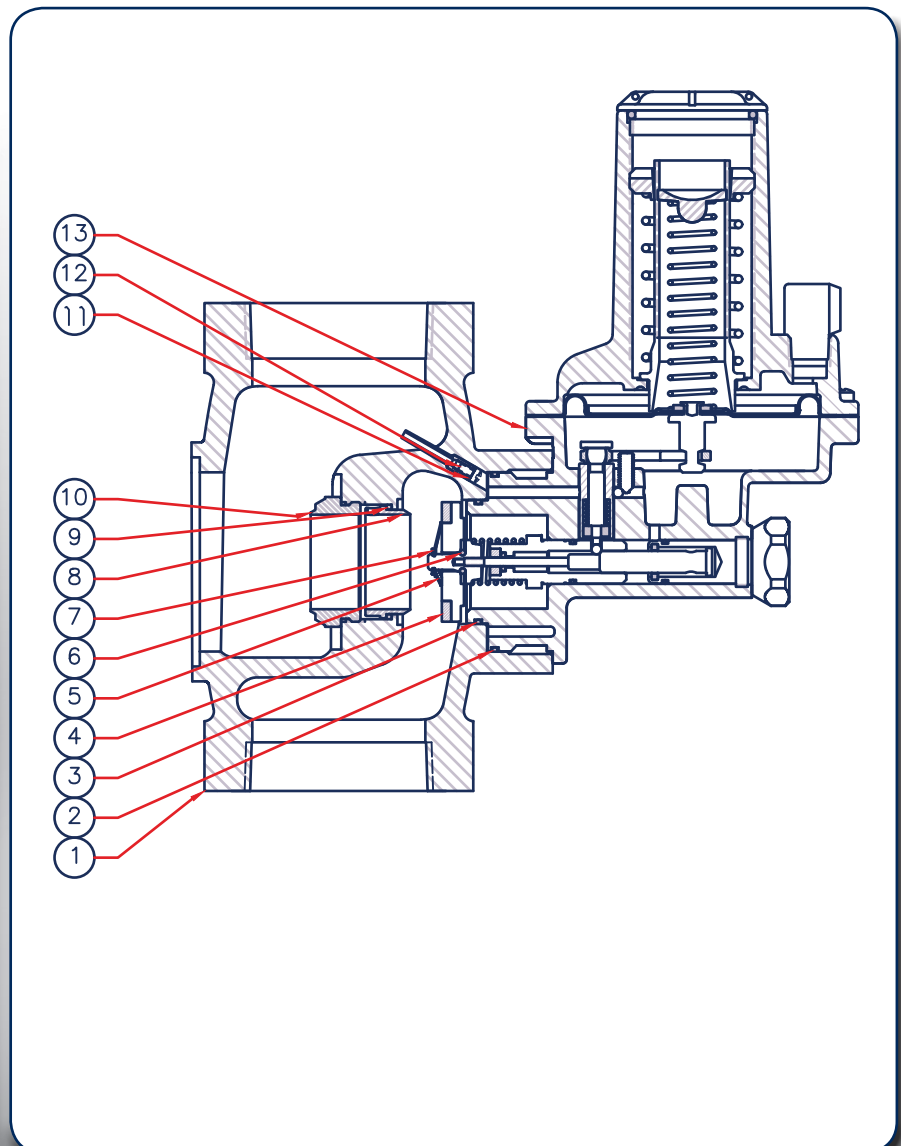
Item		Qty.	Part Number
1	1 - 1/4" NPT - Iron	1	664-671-000
	1-1/2" NPT - Iron		664-628-000
	2" NPT - Iron		664-628-001
	2" X 1-1/2" - Iron		664-628-002
	1-1/2" NPT - Steel		664-656-000
	2" NPT - Steel		664-656-001
	2" X 1-1/2" - Steel		664-656-002
	125 FF Iron		664-657-000
	150 RF - Iron		664-672-000
2	Housing O-Ring	1	649-269-000
3	Housing O-Ring	1	649-000-201
4	Disk Assembly	1	810-061-000
5	Retaining Spring	1	655-824-000
6	O-Ring	1	649-000-206
7	Retaining Ring	1	693-041-000
8	Slam Shut Seat	1	650-224-000
9	Seat O-Ring	1	649-396-002
10	<b>Main Seat Orifice</b>	1	
	1/4" Aluminum		688-016-000
	3/8" Aluminum		688-016-001
	1/2" Aluminum		688-016-002
	3/4" Aluminum		688-016-003
	1" Aluminum		688-016-004
	1-3/16" Aluminum	688-016-005	
11	Port Gasket	1	624-133-000
12	Port Screw	1	648-622-000
13	PSX2	1	See Table

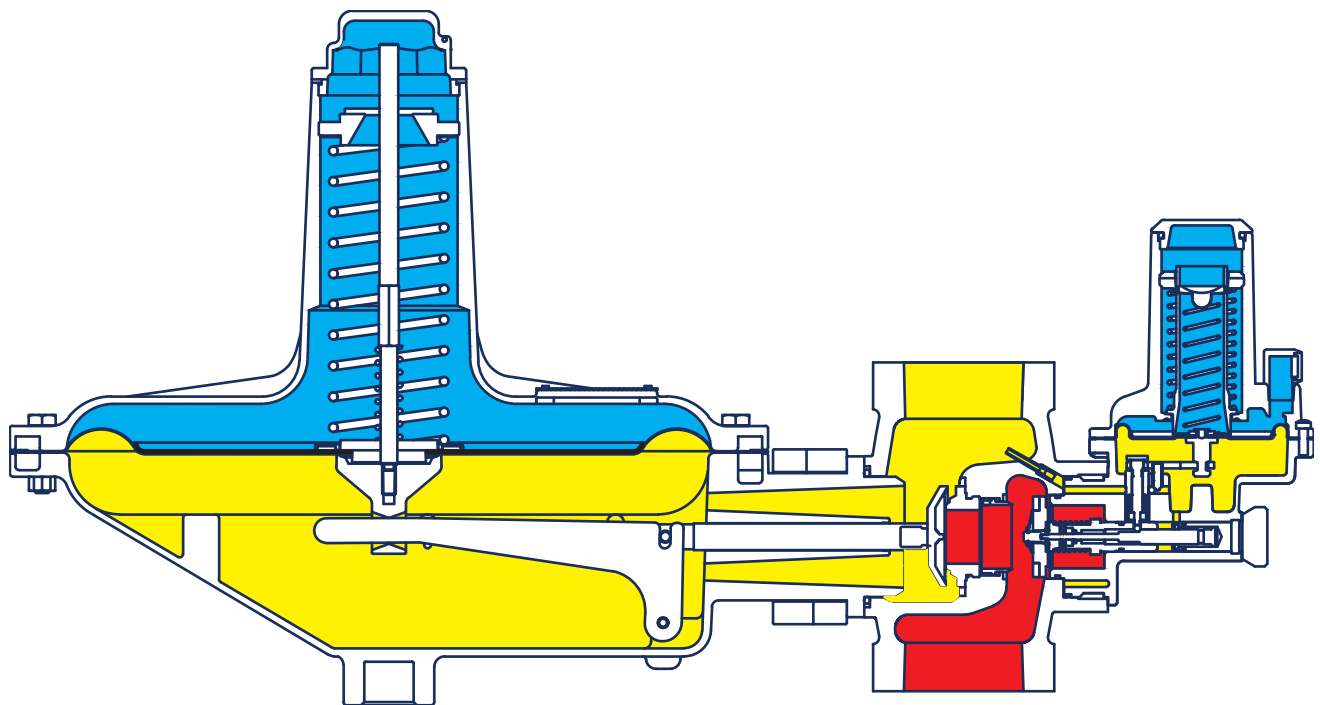



-  Inlet Pressure
-  Outlet Pressure
-  Atmospheric Pressure

## P208 / P308 Body Position

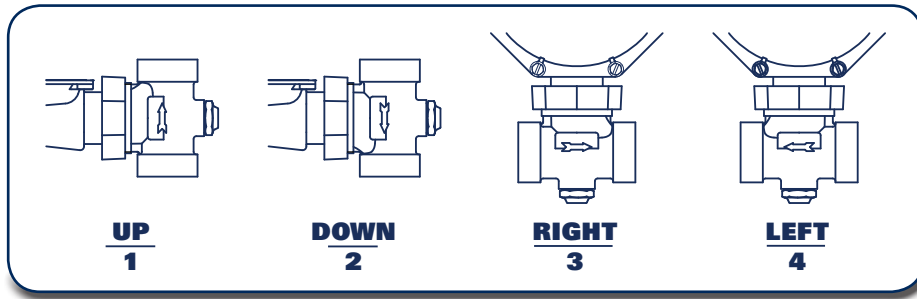

## P208 / P308 Bonnet Position

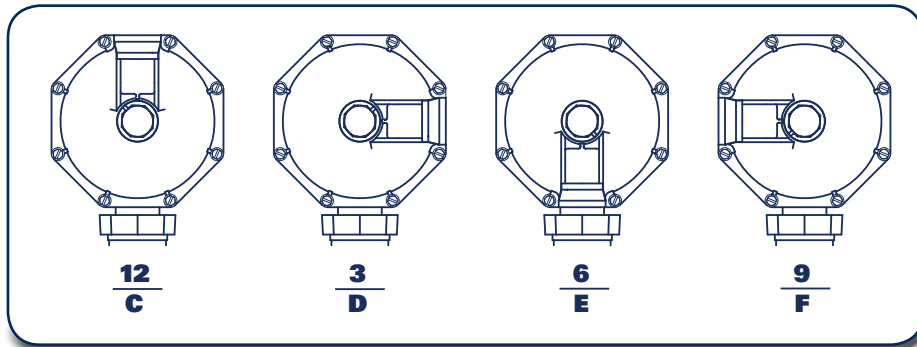

# BelGAS™

A DIVISION OF MARSH BELLOFRAM

BelGAS the leader in pressure regulator design, offers the Oil, Gas and Pipeline Industry the same precision and reliability in flow control and pressure control that the control valve market has enjoyed for over 40 years. At BelGAS, we have raised the industry standard for quality, accuracy, and dependability. Even more important is that we provide this value to our customers at an economical price.

The BelGAS product offering includes pressure regulators for gas, air and propane service; explosion-proof I/P transducers for electro-pneumatic applications; process and test gauges for pressure measurement in general and severe service and a wide assortment of bimetal thermometers and thermowells for both high and low temperature indication.

Whether the requirements call for a high pressure flow condition, a low pressure relief application or the regulation of fuel or process gas in a system, BelGAS can provide a dependable and cost effective solution.

