

# PG 103 Line Pressure Regulator

PG 103 line pressure regulators are manufactured to supply the highest performance both as Line Pressure Regulators certified to ANSI Z21.80 CSA 6.22 and Gas Appliance Regulators certified to ANSI Z21.18 CSA 6.3 and feature precise regulating control. This model is available in fixed or adjustable outlet pressures where small adjustments can be made to the outlet pressure on installation with the appliance.

## Features

- Precise regulating control of both full flow and of pilot flows
- Nitrile rubber diaphragm and washer are resistant to combustible gases
- Die-cast aluminum housing
- Regulators are supplied with vent limiter

## Materials of Construction

Body	Aluminum/Painted
Diaphragm	Nitrile
Spring	Steel

## Specifications

Inlet Pressure	2 PSIG and 5 PSIG 2" - 6" W.C.
Outlet Pressure Setting	5" - 9" W.C. 7" - 11" W.C.
Gases	Natural Gas or Propane
Pipe Size	1/2" x 1/2" NPT
Venting	Vent Limiter
Emergency Exposure Limits	65 PSIG inlet side only
Capacity Range	500,000 BTU/h
Working Temperature	-40° to 205°F (-40° to 96°C)



**ANSI/CSA CERTIFIED**

## Technical Note

For proper installation, the regulator must be installed in an upright position, as shown.

## PG 103 Dimensions

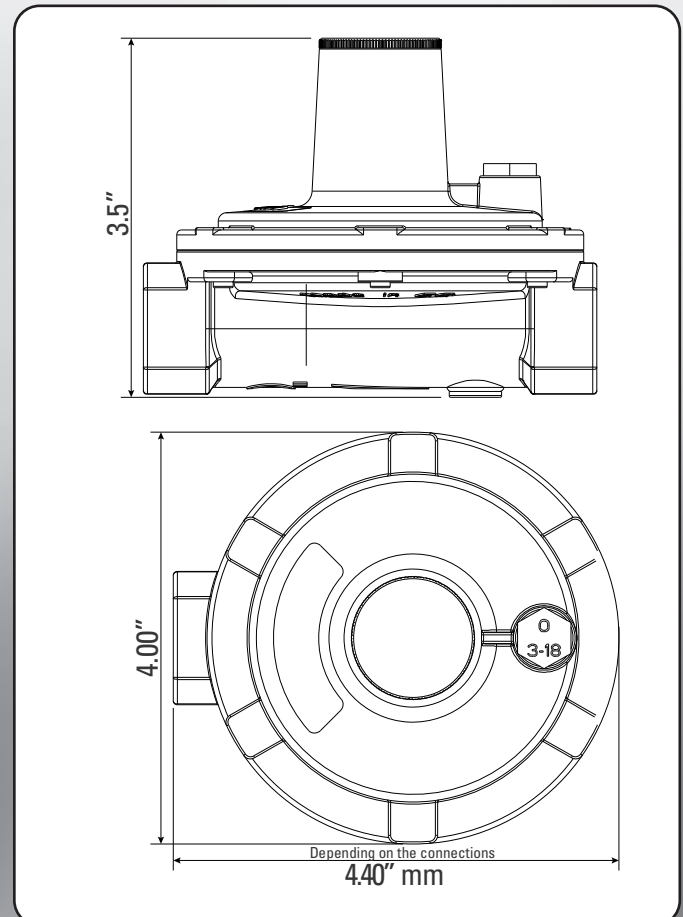

## PG 103 Part Matrix

PG10	3	04			V	000	
	↑	↑↑	↑↑↑	↑	↑		Diaphragm
	<b>3</b>						3"
							Port Size
		<b>04</b>					1/2"
							Spring Range
			<b>006</b>				2 - 6" WC
			<b>009</b>				5 - 9" WC
			<b>011</b>				7 - 11" WC
							Inlet Rating
				<b>2</b>			2 PSI
				<b>5</b>			5 PSI
							Vent Limiter
					<b>V</b>		Yes

Capacities based on 1" W.C. pressure drop from set point 0.64 sp gr gas expressed in SCFH

Outlet Pressure	Inlet Pressure				
	1/2 PSIG	3/4 PSIG	1 PSIG	2 PSIG	5 PSIG
6" W.C.	160	200	235	285	350
7" W.C.	155	200	230	280	345
8" W.C.	155	195	230	270	335
9" W.C.	145	190	215	260	325
10" W.C.	135	180	205	245	310
11" W.C.	125	170	195	235	300